

Prize Wheel Assembly Instructions (continued)

(Continued from preceding page)

III. THE WHEEL, POINTER AND GRAPHICS

(1) Unpack the **Wheel**, remove any cardboard and insert the **3-1/2" Wheel Bolt** all the way through the center of the front.

(2) Slide the two **1/2" Wheel Spacers** onto the **Wheel Bolt** and mount the **Wheel** on the **Stand** by inserting the **Wheel Bolt** through both holes of the **Crossbar**. Secure the **Wheel Bolt** with the **Wheel Washer** and **5/16" Wheel Nut** and tighten with the **1/2" Wrench** and **3/16" Allen Wrench**. The **Wheel** should spin smoothly. Ensure that the wheel is parallel with the front of the stand when tightening.

(3) Attach the **Pointer** between the slots of the **Pointer Arm** by lining up the holes and securing with the two **1/2" Pointer Bolts** and two **Small Nuts**. Tighten with the **1/8" Allen Wrench** and the **5/16" Wrench**. The **Small Nuts** can be covered with the **Small End Caps**.

(4) Attach the **Magnetic Center Cover** to the front end of the **Wheel Bolt**.

(5) Create a logo or theme by printing it on the (removable) label stock provided and applying it to the front of the **Magnetic Center Cover**. Templates are available online at www.prizewheeldealer.com

(6) Create, print, trim and insert **Prize Pieces** into the wheel slots. Templates can be found online at www.prizewheeldealer.com/templates.

(7) Start spinning!

Note: To adjust spin time, slide the **Pointer Arm** up on the **Arm Plate** (for more spins) or down (for less spins) by loosening and then retightening the **Small Nuts** behind the **Arm Plate**.

For the 31" & 40" Wheel, you have the option of two pointers.



To get more spins
and less sound use
this pointer



To get fewer spins,
and a louder sound,
use this pointer

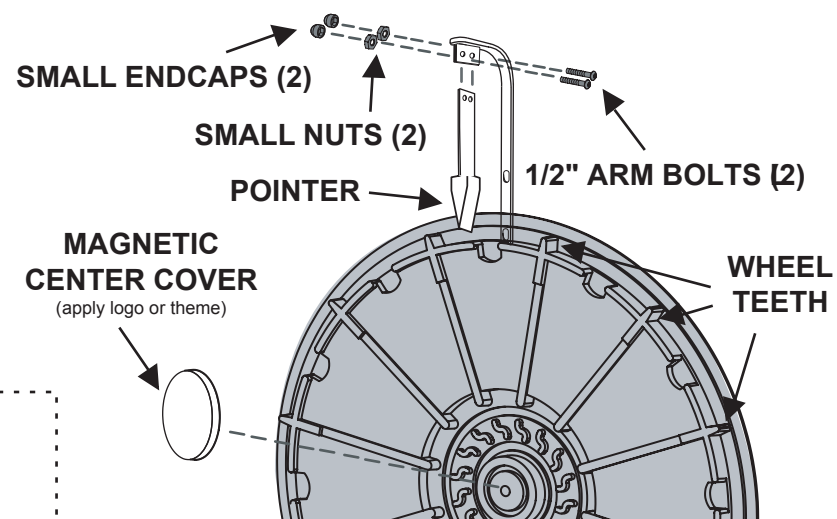
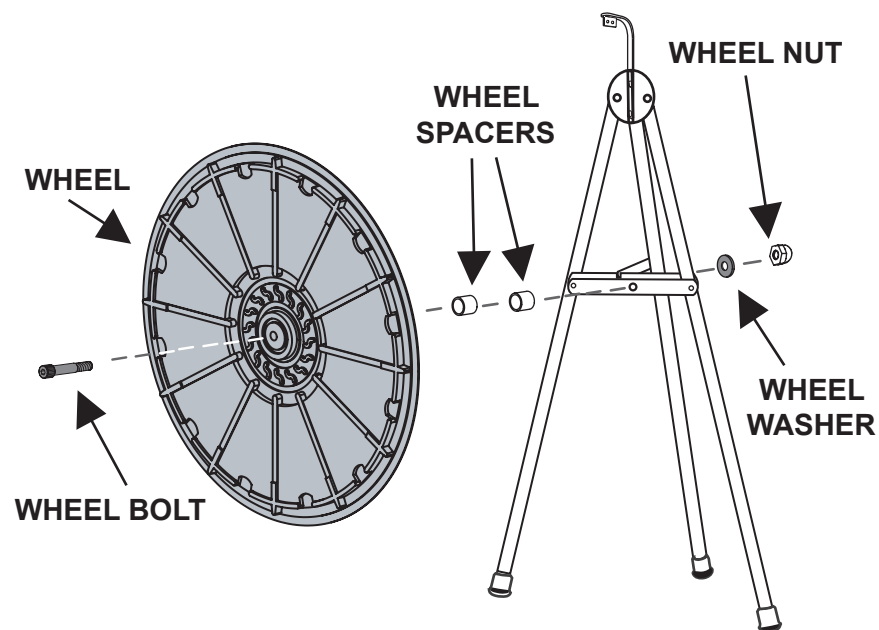

Assembly Guide

Table Top Prize Wheel Models: #63000, #63007, #63008, #63005, #63035, #63036

Floor Stand Prize Wheel Models: #63003, #63009, #63016, #63006, #63038

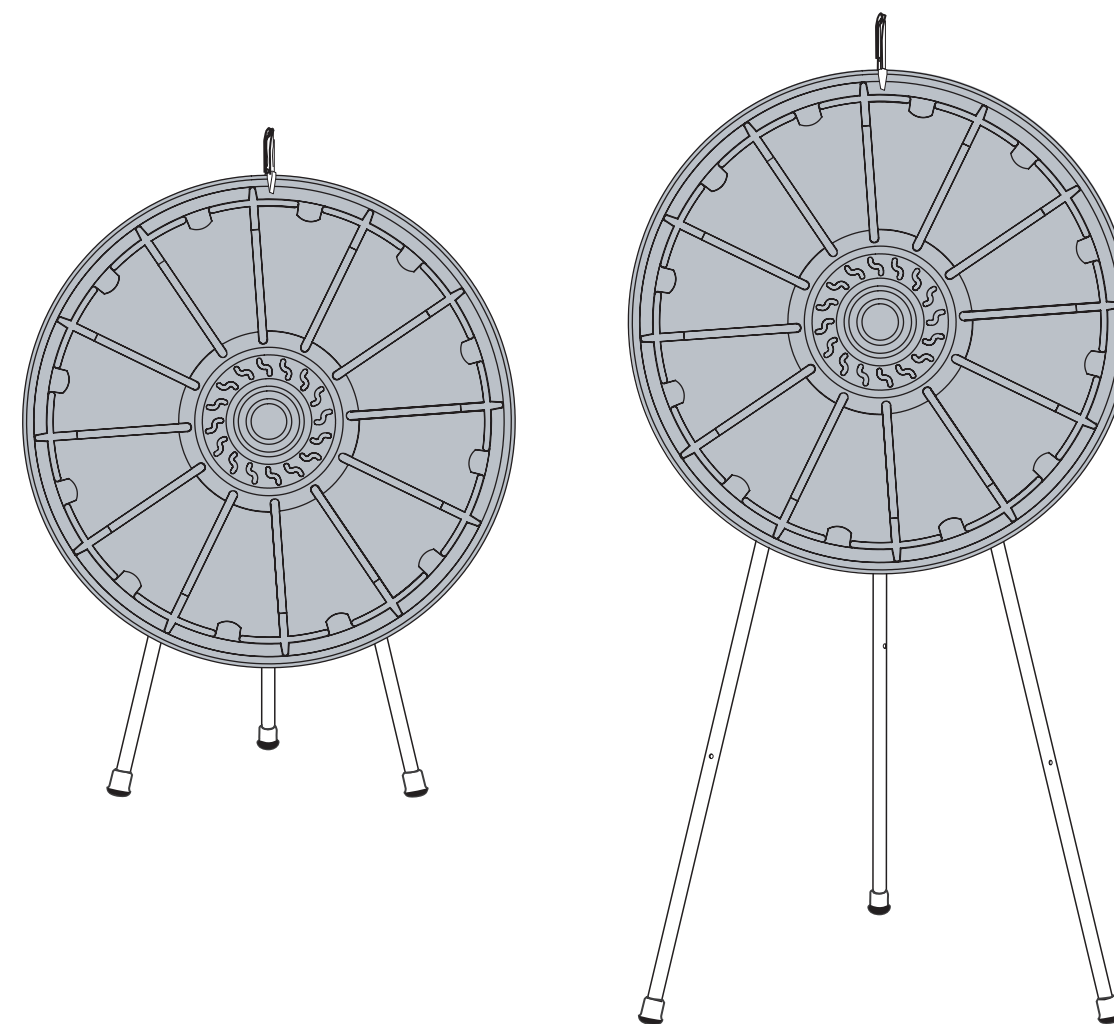

These products are not primarily intended for use by children under the age of twelve (12).

Prize Wheel Assembly Tools and Parts

TOOLS



5/16th" Wrench (Part #2071)

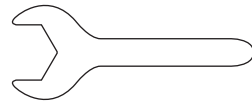

1/2" Wrench (Part #2070)



1/8th" Allen Wrench (Part #2068)



3/16th" Allen Wrench (Part #2069)

PARTS

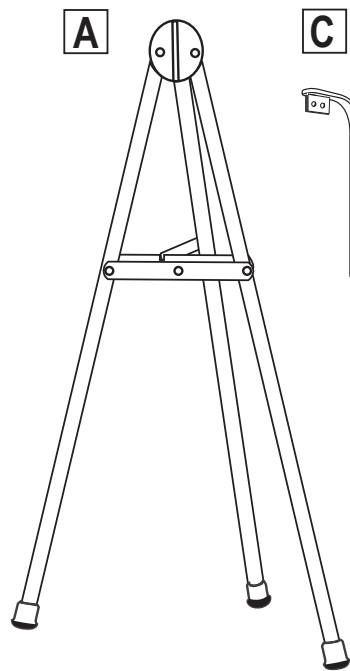

C

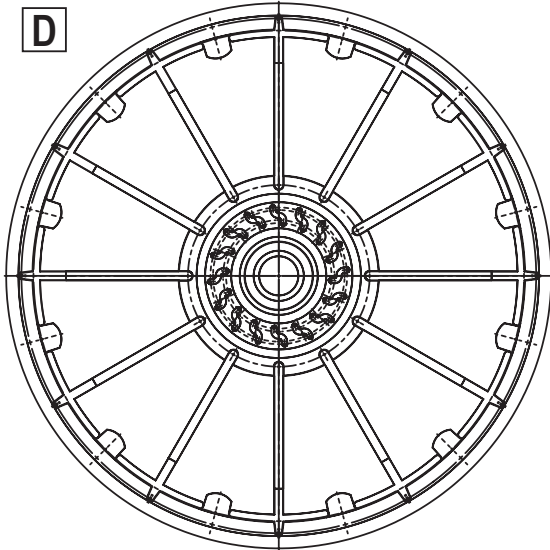

D

E

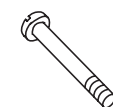

F



G



H



I



J



K



L

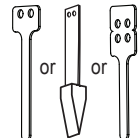

M

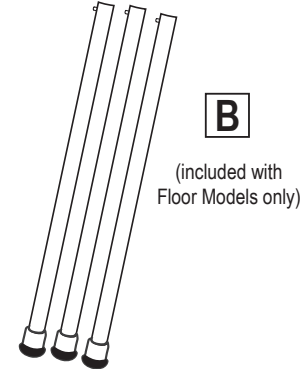
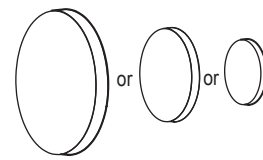

B

(included with Floor Models only)

A - Stand

B - Extension Legs (3)

C - Pointer Arm

D - Wheel

E - 3-1/2" Wheel Bolt

F - 1/2" Wheel Spacers (2)

G - Wheel Washer

H - 5/16" Wheel Nut

I - 1/2" Arm Bolts (2)

J - Small Nuts (4)

K - Small Endcaps (4)

L - Clickers

M - Magnetic Center Plate

LIMITED WARRANTY

Thermopro warrants The Prize Wheel to be free from defects in material and workmanship and agrees to repair or replace any product that proves defective for a period of two years from date of purchase. This warranty may be enforced only by the original retail customer and is not transferable. Alteration, repair, or attempted repair of the unit by anyone not authorized by Thermopro will void this warranty. Damage resulting from shipment is not covered (claims for shipping damage must be presented to the shipper).

The product must be shipped freight prepaid in the original packaging or substantially similar packaging providing an equal amount of protection. Thermopro will reimburse the cost of shipping at standard ground service freight rates to and from the repair facility (restricted to the Continental US).

Thermopro's sole liability for any defective product is limited to, at our option, the repair or replacement of the unit. Thermopro shall not be liable for any other damages, whether incidental, consequential, or damages based upon inconvenience, loss of the use of the unit, loss of time or otherwise. This warranty is exclusive and is in lieu of all other warranties, express or implied, including, but not limited to, implied warranties of merchantability or fitness for a particular purpose.

CAUTION: The Prize Wheel is plastic and will not withstand temperatures exceeding 110 degrees for a period greater than one (1) hour. Do not leave the wheel in a location where it is subject to extremely hot temperatures.
 Note: Improper storage may void the warranty. This product is not intended for use by children under 12 years of age unless under adult supervision

Prize Wheel Assembly Instructions

Before you begin, make sure you have all necessary Parts and Tools listed on the preceding page. If not, call Customer Service at (800) 523-5542.

I. EXTENSION LEGS

(Applies to Floor Models only. For Tabletop Models, skip this stage and proceed to THE STAND.)

(1) Remove **Rubber Feet** from the three **Stand Legs** and place them on the three **Extension Legs** (on opposite ends from the **Pins**).

(2) Insert **Extension Legs** into the **Stand Legs** by pressing in each **Pin** and rotating to secure it through the hole on each **Stand Leg**.

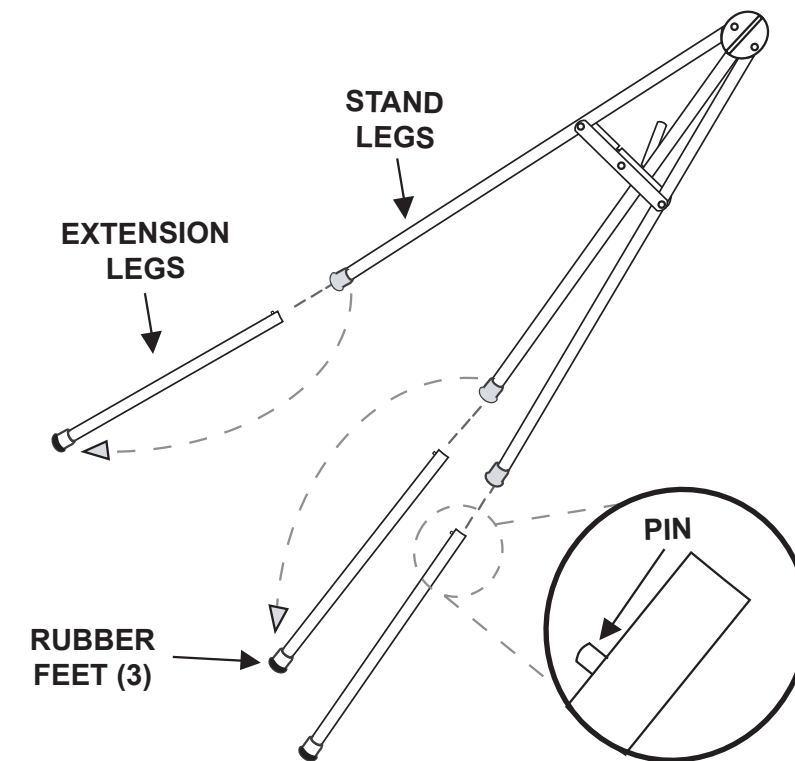

II. THE STAND

(1) Set the **Stand** upright on its **Rubber Feet** (with or without **Extension Legs**, depending on model).

(2) Free the **Support Arm** and latch it securely into the slot on the **Crossbar**.

(3) Attach the **Pointer Arm** to the **Arm Plate** (on the **Stand**) using two **1/2" Arm Bolts** and two of the **Small Nuts**. Position the **Pointer Arm** (with the curved end up, facing front) against the **Arm Plate**. Line up the top and bottom holes and insert the **Arm Bolts** through the front of the **Pointer Arm** and **Arm Plate**. Screw the **Small Nuts** onto the back of the **Arm Bolts** and tighten with the **5/16" Wrench** and **1/8" Allen Wrench**. The **Small Nuts** can be covered with two **Small End Caps**.

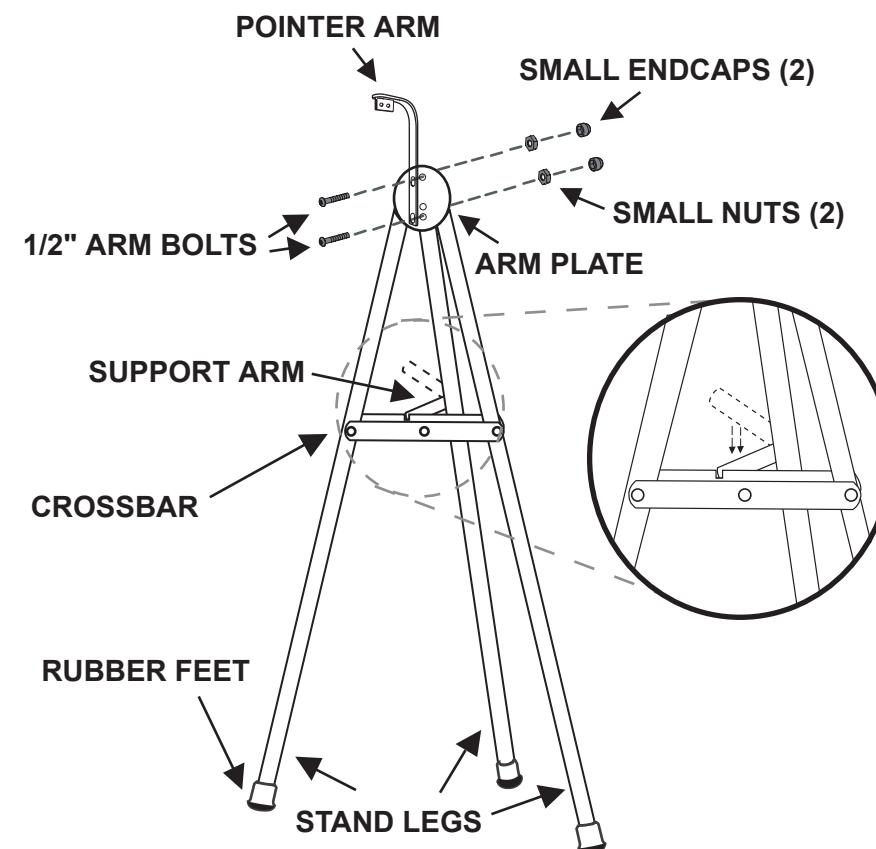

(Continued on next page)